

SLD-HY Series

Hydraulic Driven Submersible Slurry or Sand Pump
(Excavator Compatible)

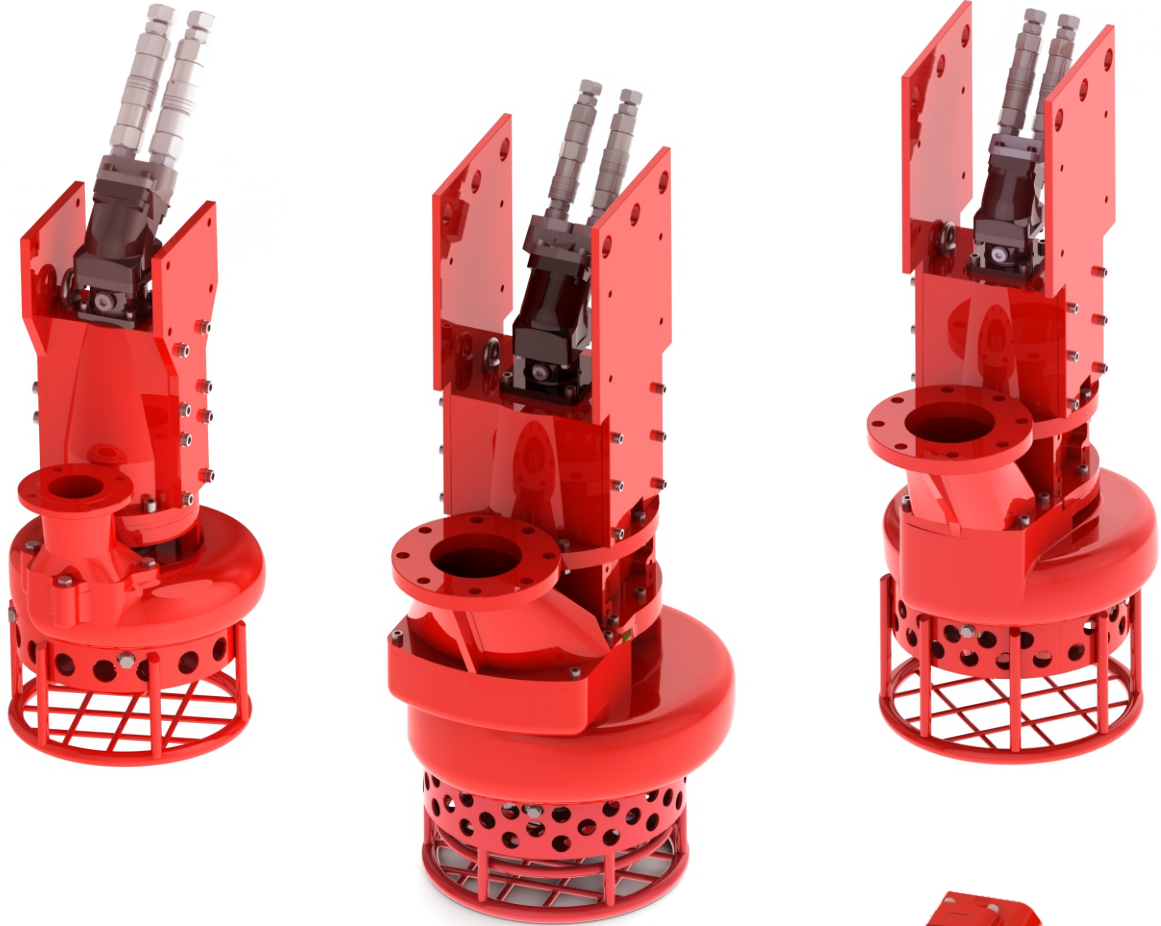

HYDRAULIC MOTOR – HAWE. Made in Germany and world wide service
Hydraulic Motor Displacement starts from 17cc, 25cc, 34cc and 47cc

Application :

1. Dredging and de-silting the river, lake and port
2. Harbour reclamation and coastal reclamation operation
3. Silt removal-sludge removal and high density slurry extraction
4. Sand and gravel pumping

Special features

1. Each pump is fitted with high chrome alloy steel agitator to assist with the reduction of solids to a slurry and which prevents the clogging of the inlet
2. Pumps casing, impeller, agitator, wear plate and delivery neck which is made high chrome 27% to ensure that long life for high wear resistance
3. All double bearing – FAG or NSK or SKF
4. SS 431 Shaft (Stainless Steel)



17cc, 25cc, 34cc, 47cc
HAWE Bend Axis -
90% volume metric efficiency

IHP: UPDATED ON 26-04-2024 | www.ihpindia.in

INDRA HYDRO TECH PUMPS PVT LTD

No.85/M, Ground Floor, Industrial Suburb, 2nd Stage Gautham Nagar, Tumkur Road
Yeshwanthpur, Bangalore 560 022, Karnataka, INDIA

Tel. : +91 80 4163 5638, Mobile: +91 94835 26899 / 80736 22800

Email : sales@ihpumps.in, Web : www.ihpindia.in | www.ihpumps.in

SLD-HY17CC-11Kw-85/13

PUMP SPECIFICATION	
Max Capacity [m ³ /hr] / US Gallons	85 / 374 US Gallons per minute
Max Head [m] / Feet	13Mtr / 43Ft
Impeller diameter [mm] / type	236/4 blades open type
Flanged bore size [DN/PN]	DN75
Solid handling [mm]	25
Weight [kg]	110

HYDRAULIC MOTOR HAWE HYDRAULIK (Germany)		
Motor Displacement [cc]	17	*Power Pack - 15 HP recommended
Max. oil flow rate [l/min]	25	Max. Torque [Nm] 47
Max. pressure Kg/cm ²	175	Speed [RPM] 1350 @ PSI 2485
Power [kW-HP of HPU]	11/15	Oil flow - 6.6 US Gallons per min.
Special Feature: Option to vary Torque and speed [pressure and flow]		

*Customer scope or HAWE Power Pack

Materials	
Motor Casing /Intermediate Housing	En-SG-500/7
Volute Casing/Impeller/Agitator/Wearplate/Delivery Flange	HiCr27%
Pump Housing Sleeve/Sharp Sleeve	SKD11
Strainer/Lifter-MS	Fabricated
Shaft	SS431
Seal and Lubricant	
Hydraulic Seal PTFE	6 nos
Dual Mechanical Seal Dia Id-45	1 no
Oil Seal Viton	2 nos
Fasteners	SS304
Oil	ISO 32

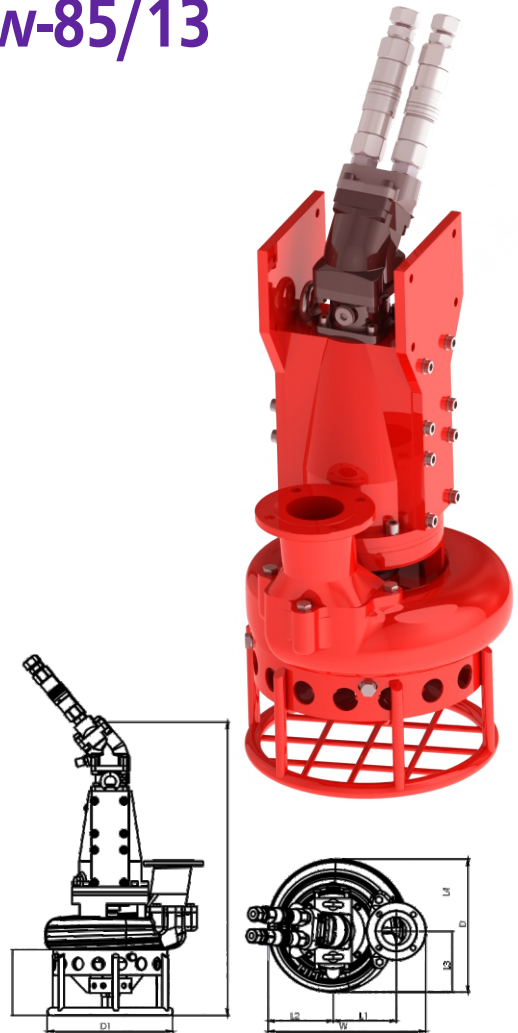

DIMENSIONS (mm)									
H	h	D	D1	L1	L2	L3	L4	W	
818	185	370	335	170	175	170	200	425	

SLD-HY17CC-11Kw-85/13

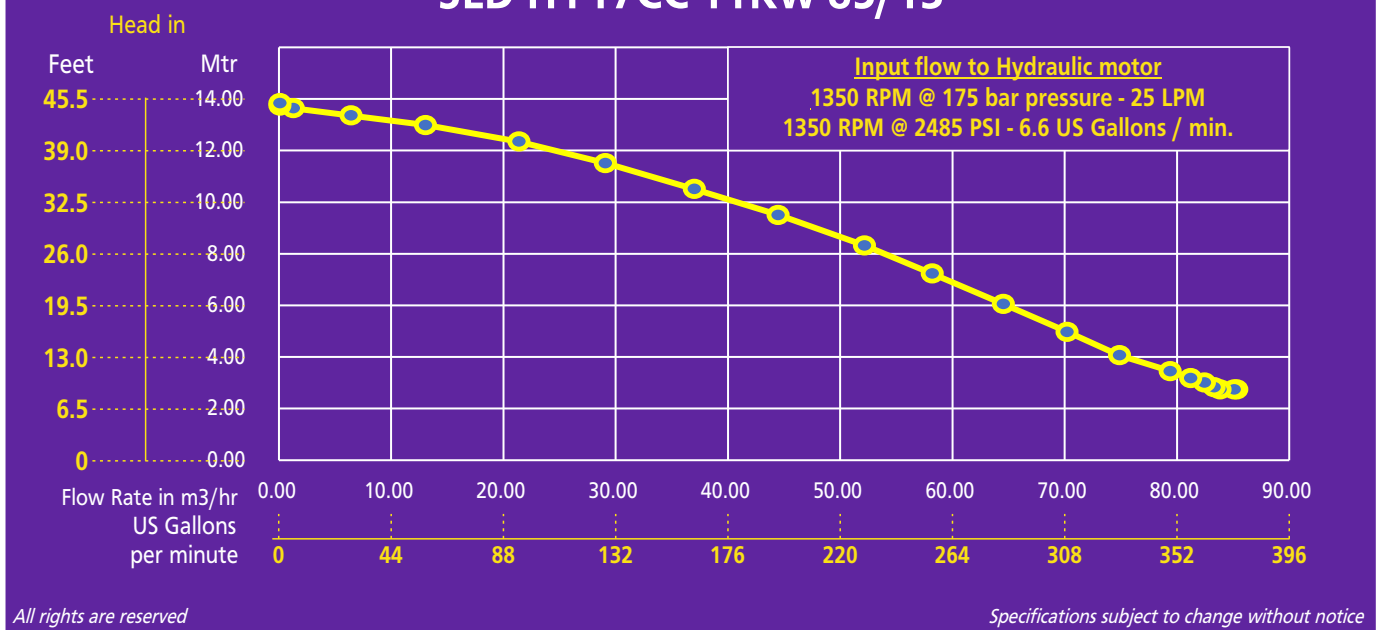

All rights are reserved

Specifications subject to change without notice

IHP: UPDATED ON 26-04-2024 | www.ihpindia.in

INDRA HYDRO TECH PUMPS PVT LTD

No.85/M, Ground Floor, Industrial Suburb, 2nd Stage Gautham Nagar, Tumkur Road
 Yeshwanthpur, Bangalore 560 022, Karnataka, INDIA

Tel. : +91 80 4163 5638, Mobile: +91 94835 26899 / 80736 22800

Email : sales@ihpumps.in, Web : www.ihpindia.in | www.ihpumps.in

SLD-HY25CC-18.5Kw-110/19

PUMP SPECIFICATION	
Max Capacity [m ³ /hr] / US Gallons	110 / 484 US Gallons per minute
Max Head [m] / Feet	19Mtr / 62Ft
Impeller diameter [mm] / type	266/4 blades open type
Flanged bore size [DN/PN]	DN100
Solid handling [mm]	30
Weight [kg]	130

HYDRAULIC MOTOR HAWE HYDRAULIK (Germany)		
Motor Displacement [cc]	25	*Power Pack - 25 HP recommended
Max. oil flow rate [l/min]	35	Max. Torque [Nm] 70
Max. pressure Kg/cm ²	175	Speed [RPM] 1350 @ PSI 2485
Power [kW-HP of HPU]	18.5/25	Oil flow - 9.2 US Gallons per min.
Special Feature: Option to vary Torque and speed [pressure and flow]		

*Customer scope or HAWE Power Pack

Materials	
Motor Casing /Intermediate Housing	En-SG-500/7
Volute Casing/Impeller/Agitator/Wearplate/Delivery Flange	HiCr27%
Pump Housing Sleeve/Sharp Sleeve	SKD11
Strainer/Lifter-MS	Fabricated
Shaft	SS431

Seal and Lubricant	
Hydraulic Seal PTFE	6 nos
Dual Mechanical Seal Dia Id-45	1 no
Oil Seal Viton	2 nos
Fasteners	SS304
Oil	ISO 32

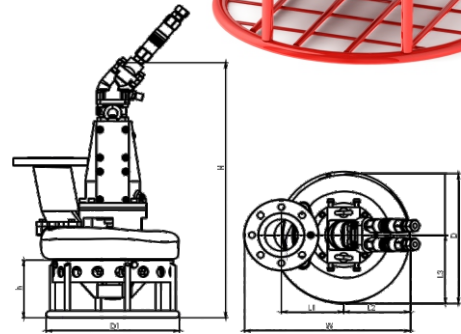

DIMENSIONS (mm)								
H	h	D	D1	L1	L2	L3	L4	W
830	190	420	410	200	200	220	200	510

SLD-HY25CC-18.5Kw-110/19

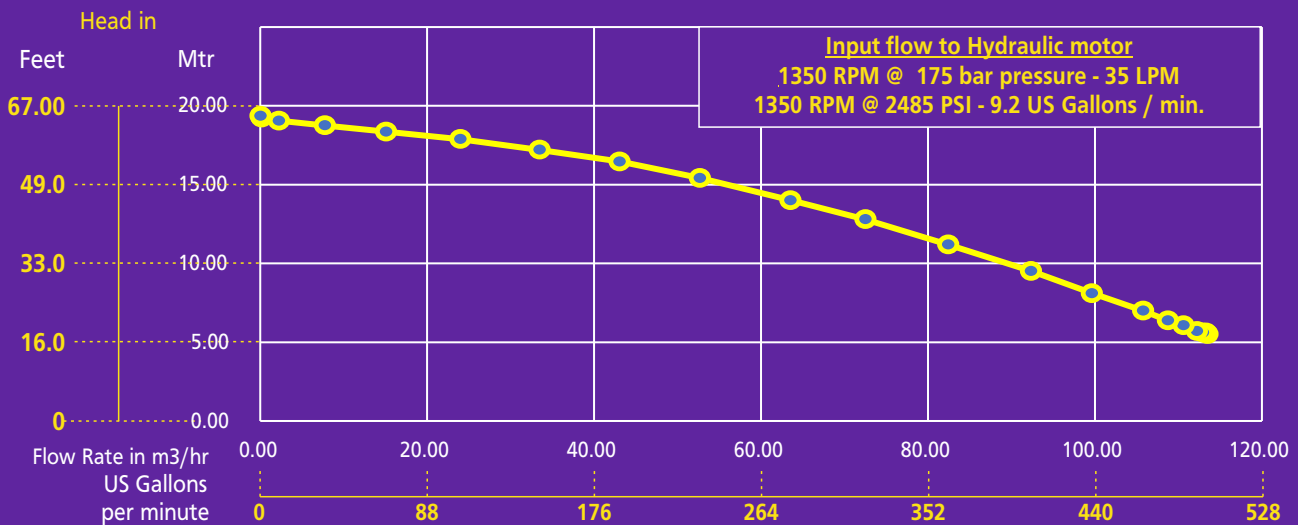

All rights are reserved

Specifications subject to change without notice

IHP: UPDATED ON 26-04-2024 | www.ihpindia.in

INDRA HYDRO TECH PUMPS PVT LTD

No.85/M, Ground Floor, Industrial Suburb, 2nd Stage Gautham Nagar, Tumkur Road

Yeshwanthpur, Bangalore 560 022, Karnataka, INDIA

Tel. : +91 80 4163 5638, Mobile: +91 94835 26899 / 80736 22800

Email : sales@ihpumps.in, Web : www.ihpindia.in | www.ihpumps.in

SLD-HY34CC-22Kw-250/21

PUMP SPECIFICATION	
Max Capacity [m ³ /hr] / US Gallons	250 / 1100 US Gallons per minute
Max Head [m] / Feet	21Mtr / 69Ft
Impeller diameter [mm] / type	285/4 blades open type
Flanged bore size [DN/PN]	DN150
Solid handling [mm]	35
Weight [kg]	240

HYDRAULIC MOTOR HAWE HYDRAULIK		
Motor Displacement [cc]	34	*Power Pack - 25 HP recommended
Max. oil flow rate [l/min]	50	Max. Torque [Nm] 95
Max. pressure Kg/cm ²	175	Speed [RPM] 1350 @ PSI 2485
Power [kW-HP of HPU]	22/30	Oil flow - 13.2 US Gallons per min.
Special Feature: Option to vary Torque and speed [pressure and flow]		

*Customer scope or HAWE Power Pack

Materials	
Casing /Intermediate Housing	En-SG-500/7
Volute Casing/Impeller/Agitator/Wearplate/Delivery Flange	HiCr27%
Pump Housing Sleeve/Sharp Sleeve	SKD11
Strainer/Lifter-MS	Fabricated
Shaft	SS431

Seal and Lubricant	
Hydraulic Seal PTFE	6 nos
Dual Mechanical Seal Dia Id-45	1 no
Oil Seal Viton	2 nos
Fasteners	SS304
Oil	ISO 32

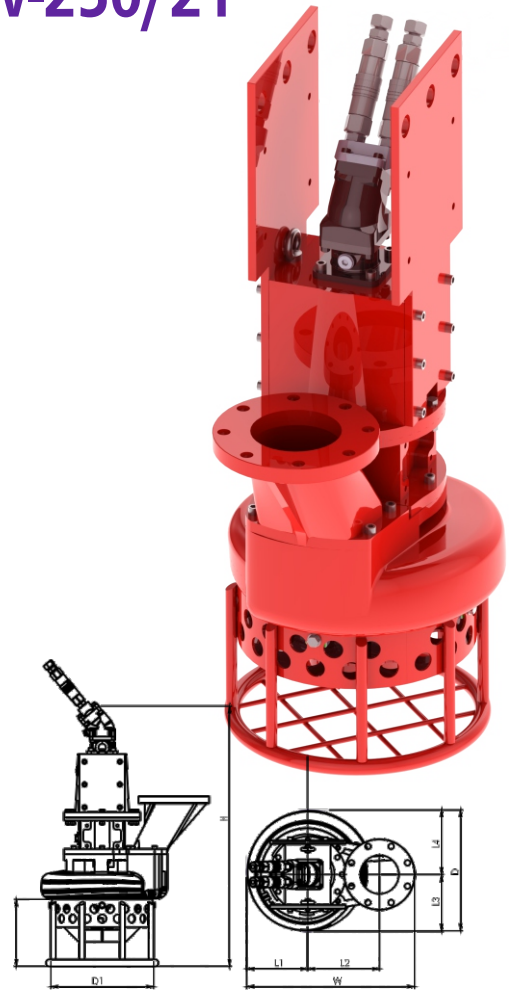

DIMENSIONS (mm)									
H	h	D	D1	L1	L2	L3	L4	W	
830	265	480	410	245	290	225	255	670	

SLD-HY34CC-22Kw-250/21

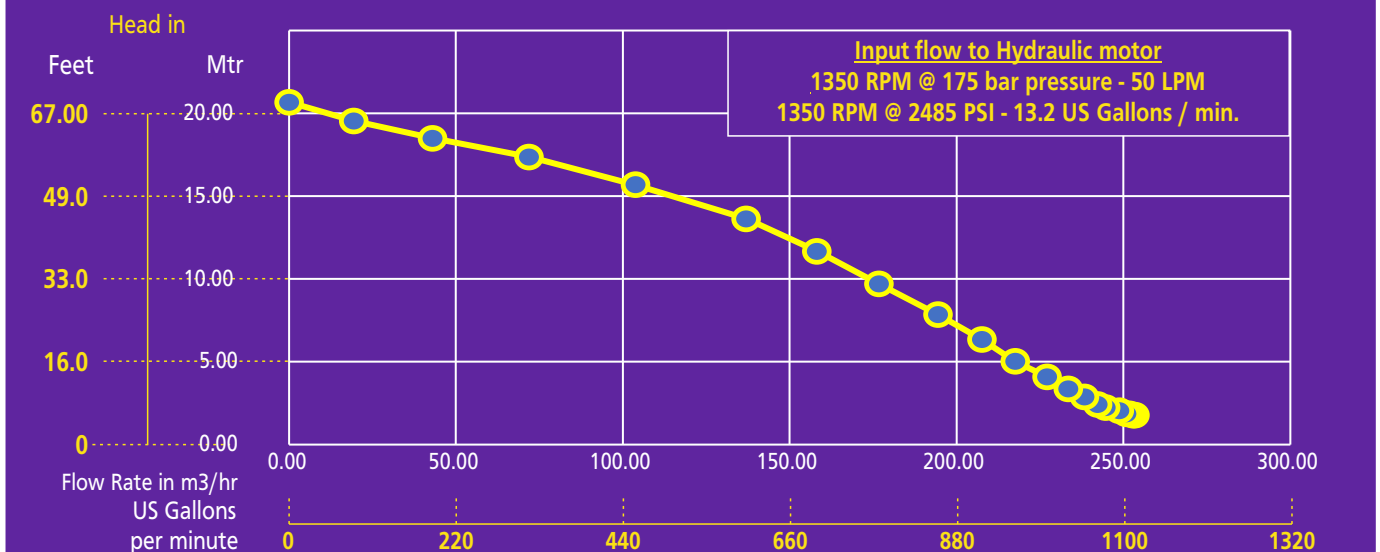

All rights are reserved

Specifications subject to change without notice

IHP: UPDATED ON 26-04-2024 | www.ihpindia.in

INDRA HYDRO TECH PUMPS PVT LTD

No.85/M, Ground Floor, Industrial Suburb, 2nd Stage Gautham Nagar, Tumkur Road
Yeshwanthpur, Bangalore 560 022, Karnataka, INDIA

Tel. : +91 80 4163 5638, Mobile: +91 94835 26899 / 80736 22800

Email : sales@ihpumps.in, Web : www.ihpindia.in | www.ihpumps.in

SLD-HY34CC-30Kw-170/30

PUMP SPECIFICATION	
Max Capacity [m ³ /hr] / US Gallons	170 / 749 US Gallons per minute
Max Head [m] / Feet	30Mtr / 98Ft
Impeller diameter [mm] / type	346/4 blades open type
Flanged bore size [DN/PN]	DN150
Solid handling [mm]	20
Weight [kg]	250

HYDRAULIC MOTOR HAWE HYDRAULIK (Germany)		
Motor Displacement [cc]	34	*Power Pack - 25 HP recommended
Max. oil flow rate [l/min]	50	Max. Torque [Nm] 108
Max. pressure Kg/cm ²	200	Speed [RPM] 1350 @ PSI 2840
Power [kW-HP of HPU]	30/40	Oil flow - 13.2 US Gallons per min.
Special Feature: Option to vary Torque and speed [pressure and flow]		

*Customer scope or HAWE Power Pack

Materials	
Motor Casing /Intermediate Housing	En-SG-500/7
Volute Casing/Impeller/Agitator/Wearplate/Delivery Flange	HiCr27%
Pump Housing Sleeve/Sharp Sleeve	SKD11
Strainer/Lifter-MS	Fabricated
Shaft	SS431

Seal and Lubricant	
Hydraulic Seal PTFE	6 nos
Dual Mechanical Seal Dia Id-45	1 no
Oil Seal Viton	2 nos
Fasteners	SS304
Oil	ISO 32

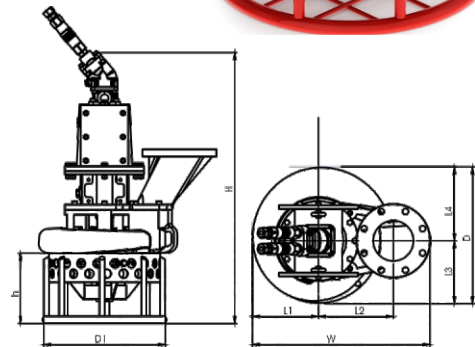
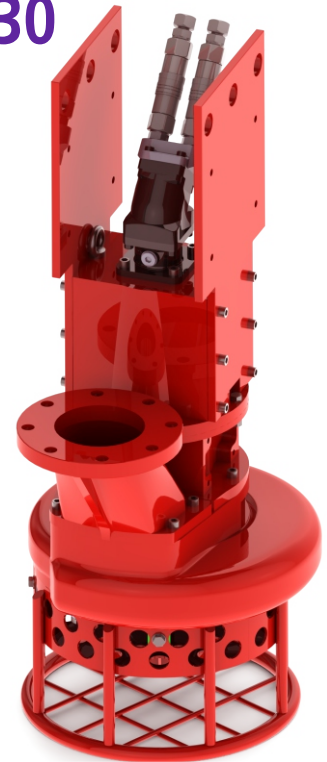

DIMENSIONS (mm)								
H	h	D	D1	L1	L2	L3	L4	W
1050	270	520	460	250	290	240	280	680

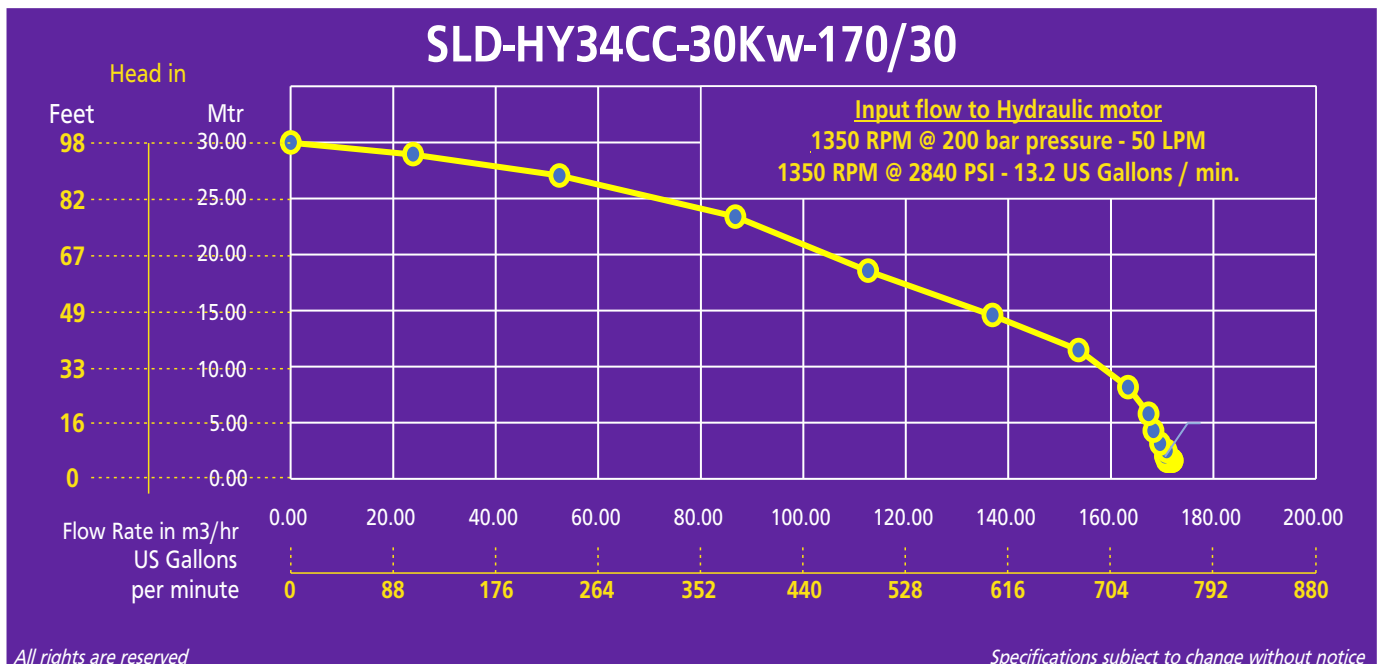

All rights are reserved

Specifications subject to change without notice

IHP: UPDATED ON 26-04-2024 | www.ihpindia.in

INDRA HYDRO TECH PUMPS PVT LTD

No.85/M, Ground Floor, Industrial Suburb, 2nd Stage Gautham Nagar, Tumkur Road

Yeshwanthpur, Bangalore 560 022, Karnataka, INDIA

Tel. : +91 80 4163 5638, Mobile: +91 94835 26899 / 80736 22800

Email : sales@ihpumps.in, Web : www.ihpindia.in | www.ihpumps.in

SLD - HY47CC -37Kw(HPU) - 318 / 28

PUMP SPECIFICATION	
Max Capacity [m ³ /hr] / US Gallons	318 / 1400 US Gallons per minute
Max Head [m] / Feet	28Mtr / 92Ft
Impeller diameter [mm] / type	340/4 blades open type
Flanged bore size [DN/PN]	DN150
Solid handling [mm]	40
Weight [kg]	330

HYDRAULIC MOTOR HAWE HYDRAULIK (Germany)		
Motor Displacement [cc]	47	*Power Pack - 50 HP recommended
Max. oil flow rate [l/min]	65	Max. Torque [Nm] 131
Max. pressure Kg/cm ²	175	Speed [RPM] 1350 @ PSI 2485
Power [kW-HP of HPU]	37/50	Oil flow - 17.2 US Gallons per min.
Special Feature: Option to vary Torque and speed [pressure and flow]		

*Customer scope or HAWE Power Pack

Materials	
Motor Casing /Intermediate Housing	En-SG-500/7
Volute Casing/Impeller/Agitator/Wearplate/Delivery Flange	HiCr27%
Pump Housing Sleeve/Sharp Sleeve	SKD11
Strainer/Lifter-MS	Fabricated
Shaft	SS431

Seal and Lubricant	
Hydraulic Seal PTFE	6 nos
Dual Mechanical Seal Dia Id-45	1 no
Oil Seal Viton	2 nos
Fasteners	SS304
Oil	ISO 32

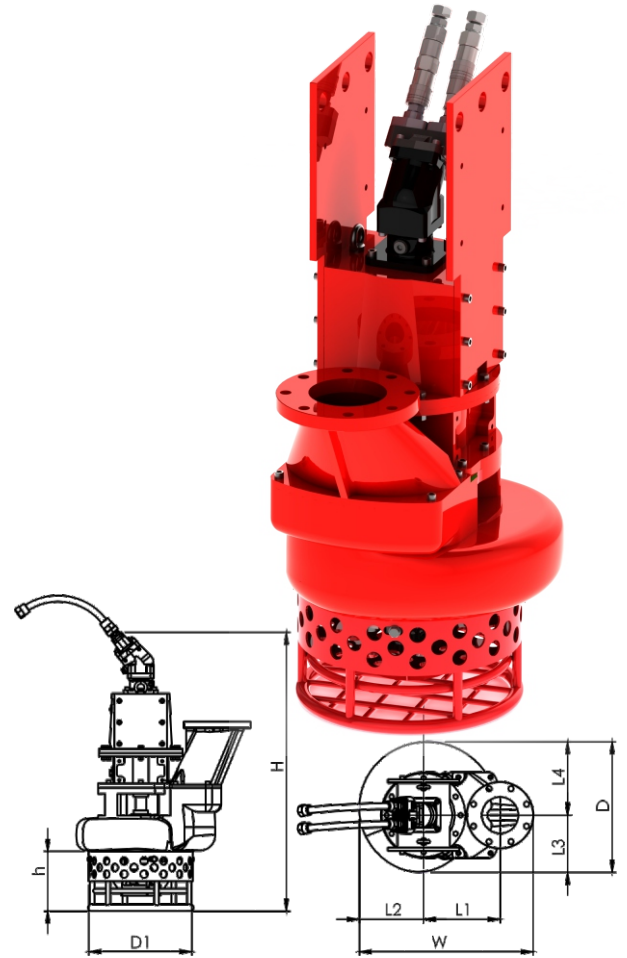

DIMENSIONS (mm)								
H	h	D	D1	L1	L2	L3	L4	W
1165	250	545	435	320	270	238	307	730

SLD - HY47CC -37Kw(HPU) - 318 / 28

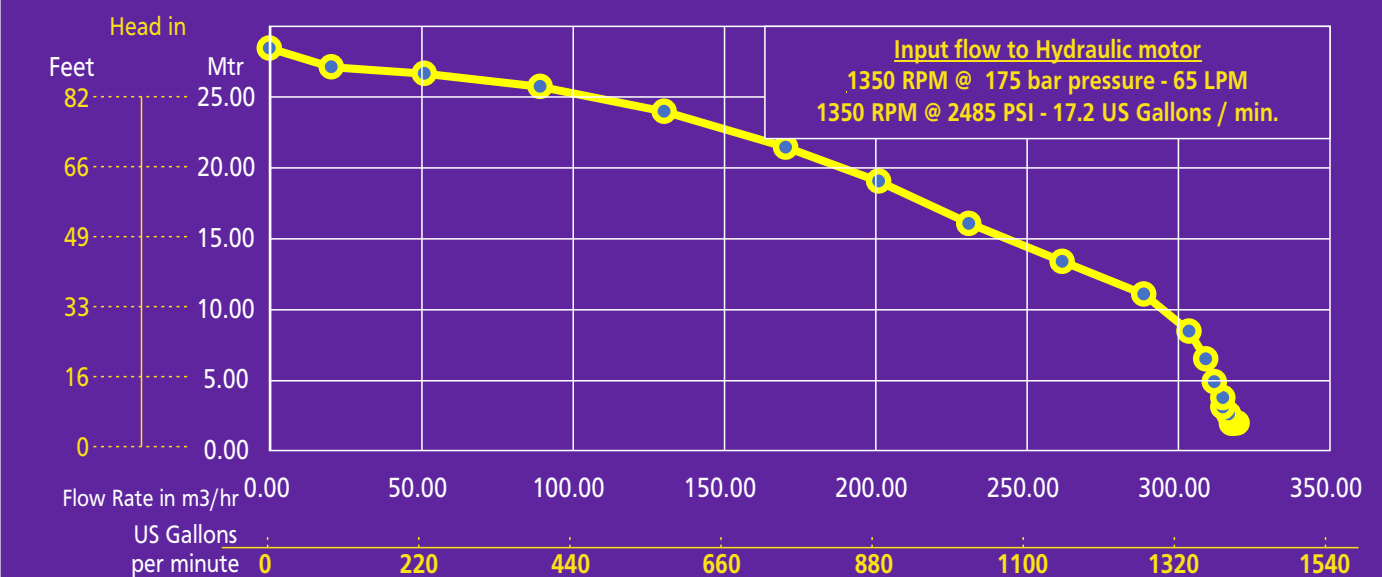

All rights are reserved

Specifications subject to change without notice

IHP: UPDATED ON 26-04-2024 | www.ihpindia.in

INDRA HYDRO TECH PUMPS PVT LTD

No.85/M, Ground Floor, Industrial Suburb, 2nd Stage Gautham Nagar, Tumkur Road
 Yeshwanthpur, Bangalore 560 022, Karnataka, INDIA

Tel. : +91 80 4163 5638, Mobile: +91 94835 26899 / 80736 22800

Email : sales@ihpumps.in, Web : www.ihpindia.in | www.ihpumps.in

SLD - HY47CC -37Kw(HPU) - 230 / 34

PUMP SPECIFICATION	
Max Capacity [m ³ /hr] / US Gallons	230 / 1013 US Gallons per minute
Max Head [m] / Feet	34Mtr / 112Ft
Impeller diameter [mm] / type	340/4 blades open type
Flanged bore size [DN/PN]	DN150
Solid handling [mm]	40
Weight [kg]	330

HYDRAULIC MOTOR HAWE HYDRAULIK (Germany)		
Motor Displacement [cc]	47	*Power Pack - 50 HP recommended
Max. oil flow rate [l/min]	65	Max. Torque [Nm] 150
Max. pressure Kg/cm ²	200	Speed [RPM] 1350 @ PSI 2840
Power [kW-HP of HPU]	37/50	Oil flow - 17.2 US Gallons per min.
Special Feature: Option to vary Torque and speed [pressure and flow]		

*Customer scope or HAWE Power Pack

Materials	
Motor Casing /Intermediate Housing	En-SG-500/7
Volute Casing/Impeller/Agitator/Wearplate/Delivery Flange	HiCr27%
Pump Housing Sleeve/Sharp Sleeve	SKD11
Strainer/Lifter-MS	Fabricated
Shaft	SS431
Seal and Lubricant	
Hydraulic Seal PTFE	6 nos
Dual Mechanical Seal Dia Id-45	1 no
Oil Seal Viton	2 nos
Fasteners	SS304
Oil	ISO 32

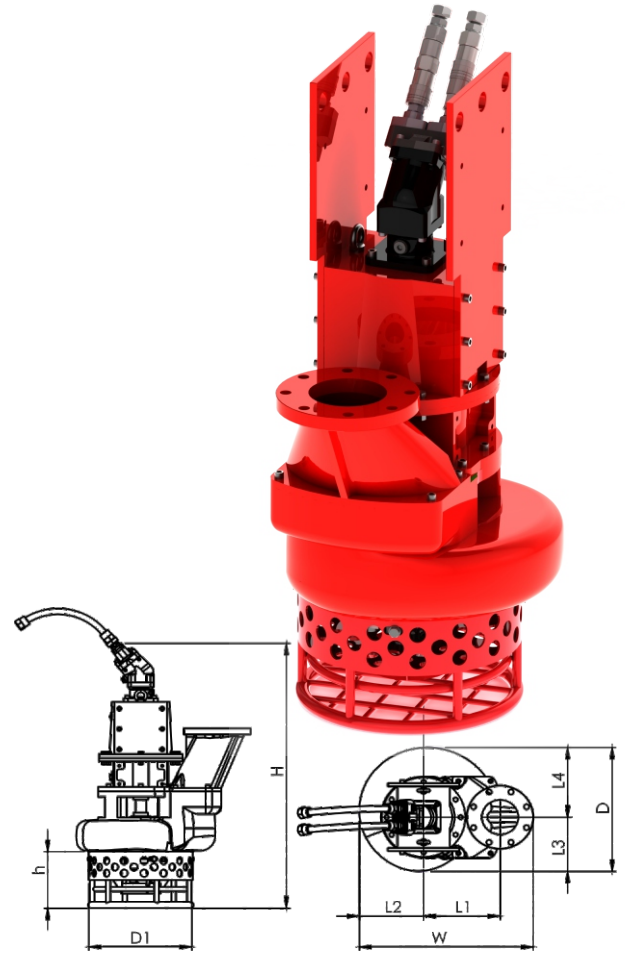

DIMENSIONS (mm)								
H	h	D	D1	L1	L2	L3	L4	W
1165	250	545	435	320	270	238	307	730

SLD - HY47CC -37Kw(HPU) - 230 / 34

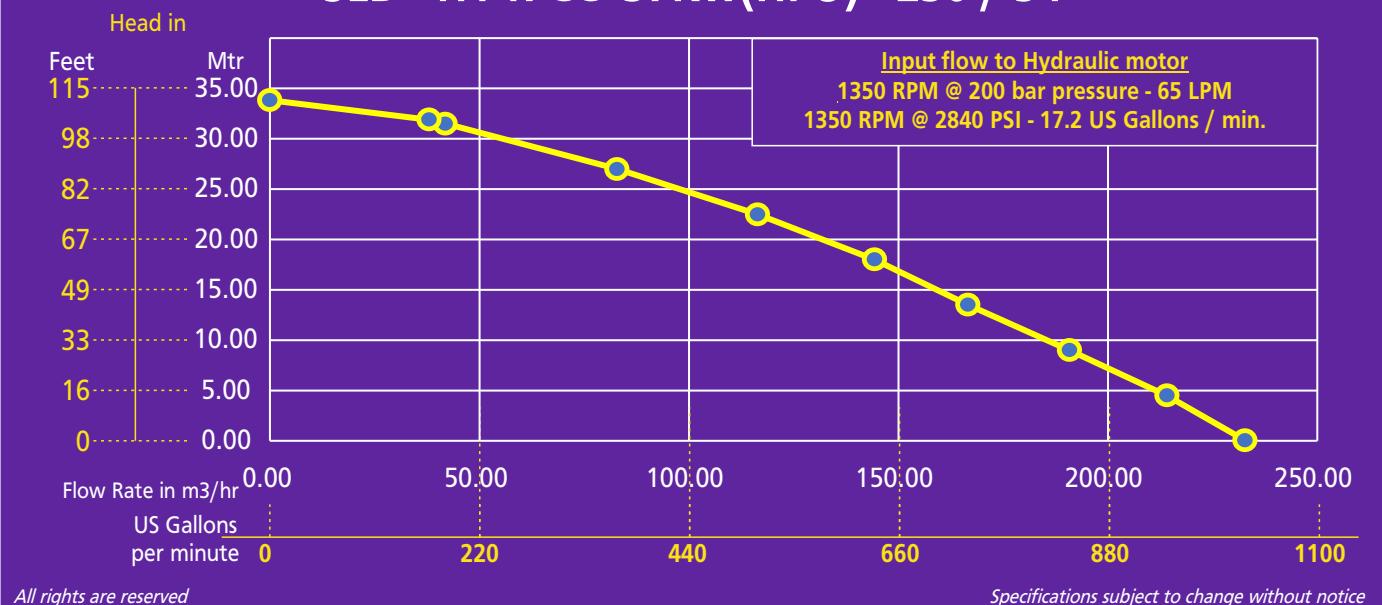

All rights are reserved

Specifications subject to change without notice

IHP: UPDATED ON 26-04-2024 | www.ihpindia.in

INDRA HYDRO TECH PUMPS PVT LTD

No.85/M, Ground Floor, Industrial Suburb, 2nd Stage Gautham Nagar, Tumkur Road
 Yeshwanthpur, Bangalore 560 022, Karnataka, INDIA

Tel. : +91 80 4163 5638, Mobile: +91 94835 26899 / 80736 22800

Email : sales@ihpumps.in, Web : www.ihpindia.in | www.ihpumps.in